



# ARCUSAFLEX-VSK

## Contents

## Coupling Information

- 04** General Technical Description

---

- 05** Advantages

---

- 06** Technical Layout

---

- 07** Materials

---

- 08** Standard Types

---

- 10** Special Types

---

- 12** General Technical Data

---

- 13** Selection of the Coupling Size

---

- 26** Data Required for Coupling Size Selection

## Dimension Tables

- 14** Type AC-VSK...F2 for Drive Shaft with Metric DIN-Flange

---

- 16** Type AC-VSK...F2 for Spicer Drive Shafts

---

- 18** Type AC-VSK...F2 for MECHANICS Drive Shafts

---

- 20** Type AC-VSK...F2.CV for Constant Velocity Drive Shafts

---

- 22** Type Double Flange Coupling

---

- 24** Type Shaft Coupling

# ARCUSAFLEX-VSK

## General Technical Description

### ARCUSAFLEX-VSK

#### Highly-flexible U-joint coupling

Drive shafts are used in a drive train when a large shaft displacement or an extended distance between the drive and the driven components must be compensated. Depending on the arrangement of the drive train components, a non-uniform motion of the speed may result, and since drive shafts exhibit some torsional flexibility, the mass of the prime mover and driven machine may induce a resonant system.

If the prime mover is an internal combustion engine, a highly flexible ARCUSAFLEX-VSK U-joint coupling (short form: AC-VSK) is required to protect the drive train from dynamic overload. Highly flexible AC-VSK U-joint couplings are capable of shifting resonant ranges below the lowest operating speed and of reducing resonance-induced vibratory torques under reversed stresses to tolerable levels.

The highly flexible AC-VSK U-joint coupling is mounted on the engine flywheel, ahead of the drive train with drive shaft. The AC-VSK U-joint coupling has an axial and radial integral bearing to accommodate the weight of the drive shaft and its reaction forces.

The AC-VSK coupling series is available in nine standard sizes covering a torque range from 390 Nm to 20 000 Nm. REICH have an extensive range of couplings to cover nearly every drive configuration. Customized solutions can be developed and manufactured even in small batches or as prototypes. In addition calculation programs are available for all necessary dimensioning.

#### **Application of the highly flexible ARCUSAFLEX-VSK U-joint couplings**

For use with combustion engines in conjunction with drive shafts for splitter gearboxes, torque converters, ship gearboxes, control gears and pump drives, for example in drives of construction equipment, excavators, cranes, marine propulsion, locomotives, pump installations and dump trucks.

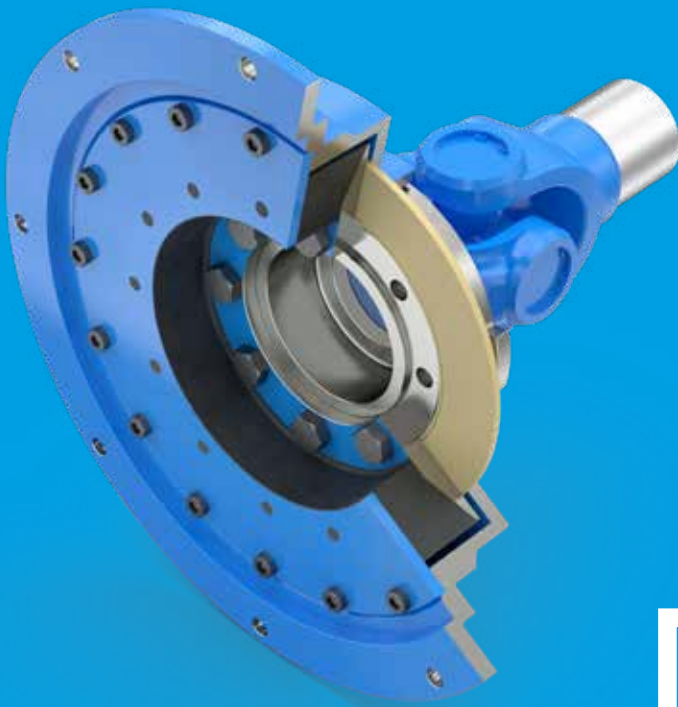

## ARCUSAFLEX-VSK

Nominal torques from 390 Nm to 20 000 Nm

## ARCUSAFLEX-VSK

### Advantages

**The most important attributes and advantages of the highly flexible ARCUSAFLEX-VSK coupling are:**

- Linear torsional deflection characteristic
- Elements available in different torsional stiffnesses
- Enhanced damping capacity through frictional damping
- Maintenance-free coupling bearings
- Radial bearing close to the cardan joint
- A variety of designs for different drive shaft configurations
- Many types with SAE connection dimensions or as specified
- Compact construction, the highly flexible element being protected by the housing
- Fail-safe device visible from the outside

# ARCUSAFLEX-VSK

## Technical Layout

The highly flexible ARCUSAFLEX-VSK U-joint couplings of type AC-VSK F2 are specially designed for fitting to flywheels of internal combustion engines. The coupling flanges (1) of the standard type therefore match engine flywheels with SAE connecting dimensions.

The highly flexible coupling element (5), comprising a rubber/steel bond and is mounted with an axial pre-load acting on the thrust

bearing (4). The output side drive shaft flange (2), used to connect the drive shaft is precisely located by means of the radial bearing (3) ensuring excellent concentricity.

The pre-loaded rubber element improves the dynamic performance of the coupling by stabilizing the support bearings, providing enhanced damping capacity due to additional frictional damping.

### ARCUSAFLEX-VSK layout and materials

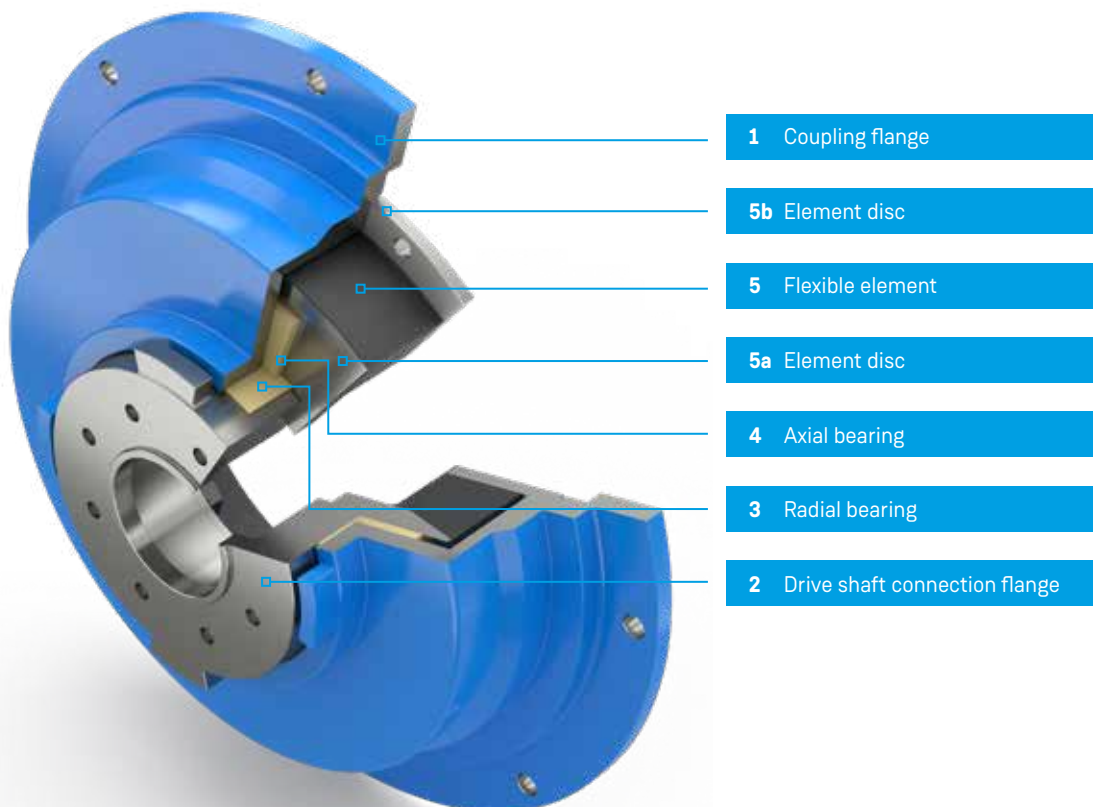

**i** The coupling shown corresponds to the version with fail-safe device

# ARCUSAFLEX-VSK

## Materials



### Materials Overview

Part No.	Designation	Materials
1	Coupling flange	Standard design spheroidal cast iron EN-GJS-400-15
2	Drive shaft connection flange	Steel (yield strength min. 360 MPa)
3	Radial bearing	Plastic-metal composite or plastic (maintenance-free)
4	Axial bearing	Composite material
5	Flexible element	Rubber according to technical details
5a, 5b	Element discs	Steel

### Technical Note

The technical data applies only to the complete coupling or the corresponding coupling elements. It is the customer's/user's responsibility to ensure there are no inadmissible loads acting on any of the components. In particular, existing connections, e.g. bolted connections, must be checked with regard to the torques to be transmitted. If necessary, further measures, such as additional reinforcement with pins, may be necessary. It is the customer's/user's responsibility to make sure the dimensioning of the shaft and keyed or other connection, e.g. shrinking or clamping connection,

is correct. All components that can rust are protected against corrosion as standard.

REICH have an extensive range of couplings and coupling systems to cover nearly every drive configuration. Customized solutions can be developed and manufactured even in small batches or as prototypes. In addition calculation programs are available for all necessary dimensioning.

# ARCUSAFLEX-VSK

## Standard Types

Type AC-VSK F2

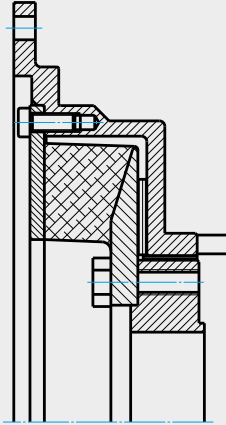

### Flange coupling

for connecting an engine flywheel to a drive shaft with metric **DIN flange**.

Type AC-VSK F2

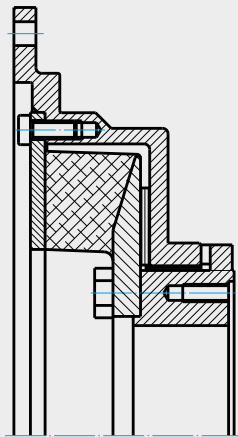

### Flange coupling

for connecting an engine flywheel to a **SPICER-drive shaft**.

Type AC-VSK F2

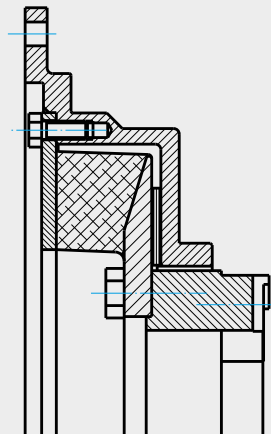

### Flange coupling

for connecting an engine flywheel to a **MECHANICS-drive shaft**.

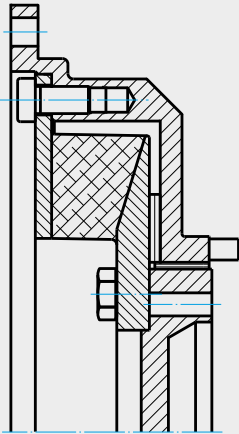

### Flange coupling

for connecting an engine flywheel to a constant velocity shaft.

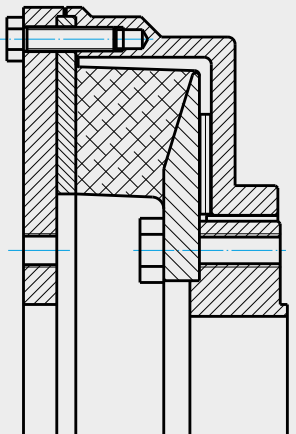

### Double flange coupling

for connecting a flange with drive shaft connection to a drive shaft.

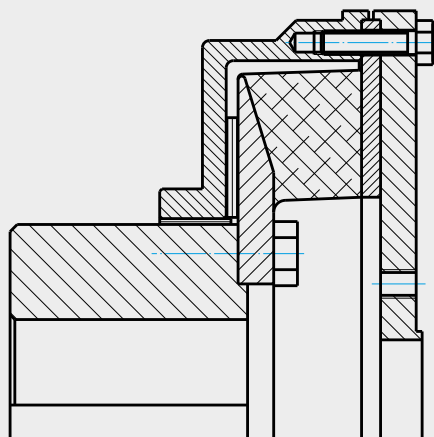

### Shaft coupling

for connecting a shaft to a drive shaft.

# ARCUSAFLEX-VSK

## Special Types

Short Type AC-VSK F2

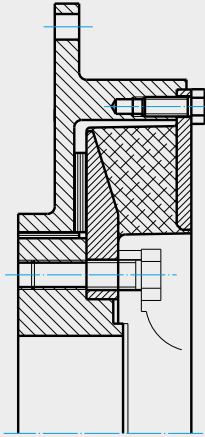

### Flange coupling

with narrow axial width, i.e. short installation length, for connecting an engine flywheel to a drive shaft.

Type AC - F2 FG-GL

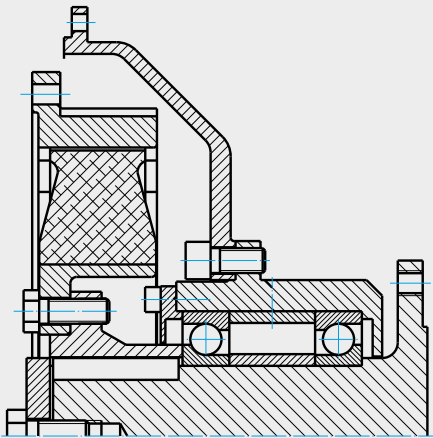

### Flange coupling

Highly torsionally flexible ARCUSAFLEX® flange coupling with integral shaft support to connect a cardan shaft having a large deflection angle, also available with integrated clutch. A separate shaft bearing support attached to the engine housing keeps the crankshaft of the engine free from the additional stresses arising from cardan shaft deflection.

Type FD-VSK

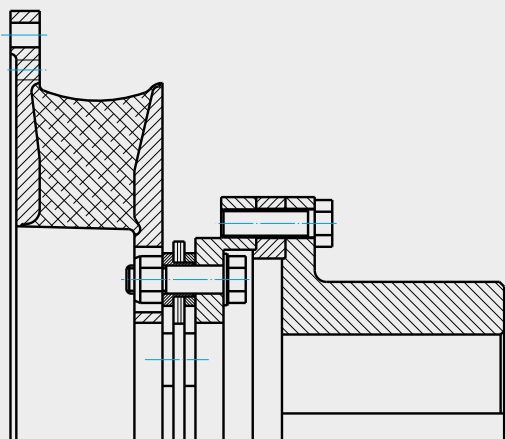

### AC with coupling housing

Highly torsionally flexible VSK coupling element in combination with FLEXDUR disc assembly. To compensate for a large shaft displacement (e.g. with a flexibly mounted engine).

The coupling element compensates for the radial shaft displacement and the FLEXDUR disc assembly compensates for the axial misalignment; for torques up to 28 000 Nm.



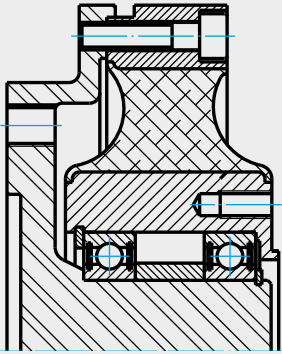

**Highly flexible torsionally optimized coupling**

used in connection with a drive shaft, constant velocity shaft, flange or splined shaft profile. An extra catalogue is available.

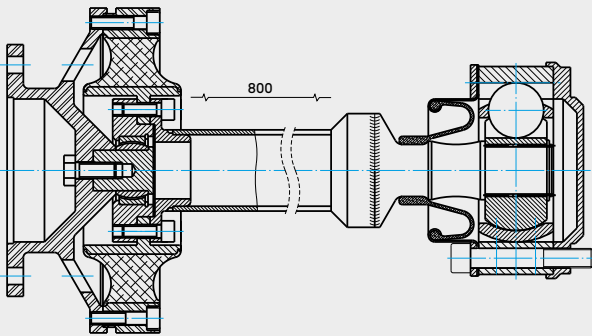

**Highly flexible torsionally optimized coupling for engine test benches**

Available designs: Integrated bearing with cardan shafts, integrated bearing with constant velocity shafts, double element coupling with/without telescopic unit.

# ARCUSAFLEX-VSK

## General Technical Data



### Standard Type

Coupling size	Element version	Nominal torque	Maximum torque	Continuous fatigue torque	Permissible power loss	Dynamic torsional stiffness	Maximum speed	
		$T_{KN}$ [Nm]	$T_{K max}$ [Nm]				$T_{KW}$ (10 Hz) [Nm]	$P_{KV}$ (30 °C) [W]
AC-VSK 15	EN	390	1170	140	120	2400	4500 4000	8" 10"
	WN	450	1350			2900		
	NN	560	1680			4500		
AC-VSK 25	EN	710	2130	250	190	4500	4000 3500	10" 11.5"
	WN	820	2440			5200		
	NN	1000	3000			8000		
AC-VSK 35	EN	1100	3300	400	220	7800	3600 3500 3000	10" 11.5" 14"
	WN	1250	3750			9500		
	NN	1600	4800			14000		
AC-VSK 45	EN	1400	4200	525	240	9000	3500 3000	11.5" 14"
	WN	1600	4800			11000		
	NN	2100	6300			17000		
AC-VSK 50	EN	2000	6000	750	280	14000	3000 2300	14" 18"
	WN	2300	6900			18000		
	NN	3000	9000			24000		
AC-VSK 55	EN	3500	10500	1250	335	24000	2600 2300	14" 18"
	WN	4000	12000			30000		
	NN	5000	15000			45000		
AC-VSK 60	EN	4400	13200	1550	375	35000	2500 2300	14" 18"
	WN	5000	15000			42000		
	NN	6200	18600			65000		
AC-VSK 70	EN	7000	21000	2500	445	50000	2300 2100	18" 21"
	WN	8000	24000			62000		
	NN	10000	30000			93000		
AC-VSK 85	EN	14000	42000	5000	650	96000	2100	21"
	WN	16000	48000			120000		
	NN	20000	60000			185000		

**i** 1) The relative damping relates only to the elastomer. The frictional damping of the bearings has to be considered separately, depending on the type of operation

### Shore hardness ShA, Resonance factor $V_R$ and relative damping $\Psi$

Element version	Sh A	$V_R$	$\Psi$
EN	50	6.28	1.0
WN	55	5.03	1.25
NN	65	4.49	1.40

**i** Due to the physical properties of the rubber material, the measurable rubber hardness is subject to a variation that is defined as  $\pm 5^\circ$  Shore A according to DIN 53505. However, this variation is minimized by our own rubber production.

# ARCUSAFLEX-VSK

## Selection of the Coupling Size

The selected coupling for internal combustion engine drives should be verified by a torsional vibration analysis which we will provide on request. A preliminary selection of the coupling can, however, be made based on the continuous engine power being transmitted.

**In selecting the coupling size the following should be satisfied:**

- The **nominal torque of the coupling  $T_{KN}$**  must be taken into account at every temperature and operating load of the coupling, whilst observing the service factors  $S$  (e.g: temperature factor  $S_t$ ) shall be at least equal to the maximum nominal torque on the drive side  $T_{AN}$ ; the temperature in the immediate vicinity of the coupling must be taken into account.

$$T_{KN} \geq T_{AN} \cdot S_t$$

- The **nominal torque on the drive side  $T_{AN}$**  is calculated with the driving power  $P_{AN}$  and the coupling speed  $n_{AN}$ .

$$T_{AN} \text{ [Nm]} = 9550 \frac{P_{AN} \text{ [kW]}}{n_{AN} \text{ [min}^{-1}\text{]}}$$

- The **temperature factor  $S_t$**  allows for the decreasing load capacity of the coupling when affected by elevated ambient temperatures in the vicinity of the coupling.

Temperature t	60 °C	70 °C	80 °C	>80 °C
$S_t$	1.25	1.4	1.6	on request

- A continuous torsional vibration analysis to verify the coupling selection should confirm that the permissible **continuous fatigue torque  $T_{KW}$**  is at least equal to the highest fatigue torque  $T_W$  under reversing stresses encountered throughout the operating speed range while taking into account the temperature and frequency.

$$T_{KW} (10 \text{ Hz}) \geq T_W \cdot S_t \cdot S_f$$

- The **frequency factor  $S_f$**  allows for the frequency dependence of the permissible continuous fatigue torque under reversing stresses  $T_{KW} (10 \text{ Hz})$  with an operating frequency  $f_x$ .

$$S_f = \sqrt{\frac{f_x}{10}}$$

# ARCUSAFLEX-VSK

Type AC-VSK...F2 for Drive Shafts with Metric DIN Flange

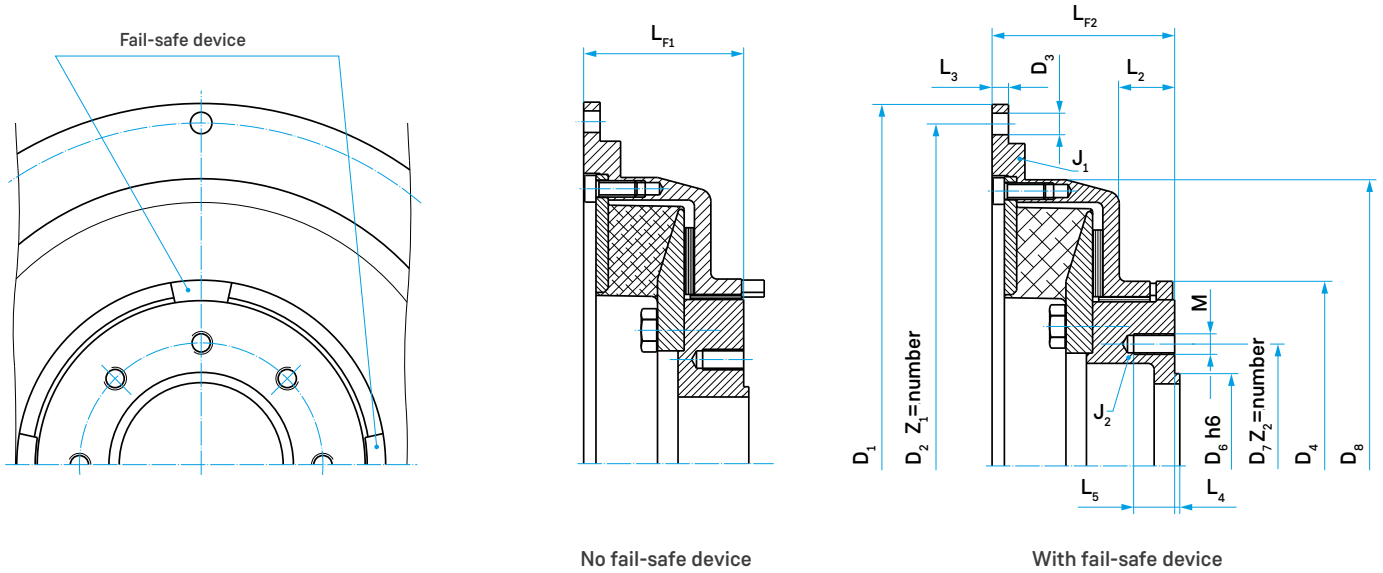

## Coupling details

Engine flywheels with SAE-connecting dimensions according to J 620

Coupling size	Flywheel connection dimensions											Drive shaft connecting dimensions								Total mass <sup>5)</sup> [kg]					
	SAE Size	D <sub>1</sub> [mm]	D <sub>2</sub> [mm]	D <sub>3</sub> [mm]	Z <sub>1</sub>	D <sub>4</sub> [mm]	D <sub>8</sub> [mm]	L <sub>2</sub> [mm]	L <sub>3</sub> [mm]	L <sub>F1</sub> [mm]	L <sub>F2</sub> [mm]	Flange Ø	D <sub>6</sub> h6 [mm]	D <sub>7</sub> [mm]	Z <sub>2</sub> x M <sup>2)</sup> [mm]	L <sub>4</sub> [mm]	L <sub>5</sub> [mm]	J <sub>1</sub> [kgm <sup>2</sup> ]	J <sub>2</sub> <sup>5)</sup> [kgm <sup>2</sup> ]						
- 15. <sup>1)</sup> F2	8	263.5	244.5	10.5	6							100	57	84.0	6 x M8			0.061		9.1					
	10	314.3	295.3	10.5	8	140	215	18	8	57	68	120	75	101.5	8 x M10	2.0	16	0.089	0.008	11.0					
- 25. <sup>1)</sup> F2	10	314.3	295.3	10.5	8	144	260	22	10	75.5	86.5	120	75	101.5	8 x M10	2.0	20	0.171	0.021	15.3					
	11.5	352.4	333.4	10.5																					
- 35. <sup>1)</sup> F2	10	314.3	295.3	10.5	8	180	279	17.3	16	79.3	90.3	120	75	101.5	8 x M10	2.0	20	0.140	0.045	16.6					
	11.5	352.4	333.4	10.5					8									0.176		18.0					
	14	466.7	438.2	13.0					8									0.345		21.5					
- 45. <sup>1)</sup> F2	11.5	352.4	333.4	10.5	8	180	314	24	26	89	100	150	90	130.0	8 x M12	2.5	20	0.280	0.057	22.8					
	14	466.7	438.2	13.0					10									0.508		28.3					
- 50. <sup>1)</sup> F2	14	466.7	438.2	13.0	8	210	352	35	12	103	120	150	90	130.0	8 x M12	2.5	25	0.650	0.109	36.0					
	18	571.5	542.9	17.0								180						110		155.5	8 x M14	3.0	30	1.130	42.3
- 55. <sup>1)</sup> F2	14	466.7	438.2	13.0	8	285	417	35	28	115	130	180	110	155.5	8 x M14	3.0	25	1.037	0.332	90.6					
	18	571.5	542.9	17.0					6			15						225		140	196.0	8 x M16	1.667	0.327	98.4
																		250		140	218.0	8 x M18	4.0	30	
- 60. <sup>1)</sup> F2	14	466.7	438.2	13.0	8	300	424	47	25 <sup>3)</sup>	119.5	136.5	225	140	196.0	8 x M16	4.0	45	1.109	0.430	60.6					
	18	571.5	542.9	17.0					6			15						130.5		147.5	250	140	218.0	8 x M18	1.862
- 70. <sup>1)</sup> F2	18	571.5	542.9	17.0	12	348	510	45	15	139	160	250	140	218.0	8 x M18	4.0	30	2.567	0.923	96.7					
	21	673.1	641.4	17.0								12						285		175	245.0	8 x M20	5.0	35	3.606
- 85. <sup>1)</sup> F2	21	673.1	641.4	17.0	12	440	610	64	36 <sup>4)</sup>	158.5	179.4	285	175	245.0	8 x M20	5.0	35	7.206	2.171	165					
												315									175	280.0	8 x M22	5.0	35

1) Element version according to "General Technical Data"

2) Alternative connection threads on request

3) Centering depth 9 mm

4) Centering depth 14 mm

5) Values without fail-safe device

## Ordering example

Coupling size	Element version according to "General Technical Data"	Flange version	SAE flywheel connection	Drive shaft flange Ø	Version with fail-safe device
---------------	---	----------------	-------------------------	----------------------	-------------------------------

AC-VSK 50	.WN.	F2.	14.	150.	DS
-----------	------	-----	-----	------	----

Coupling designation: AC-VSK 50 .WN. F2. 14. 150. DS

# ARCUSAFLEX-VSK

Type AC-VSK...F2 for SPICER Cardan Shafts

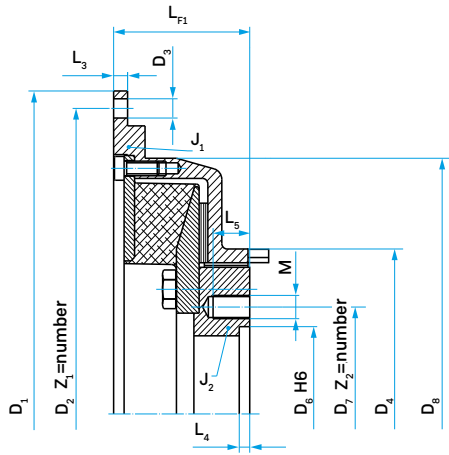

Fig. 1: no fail-safe device

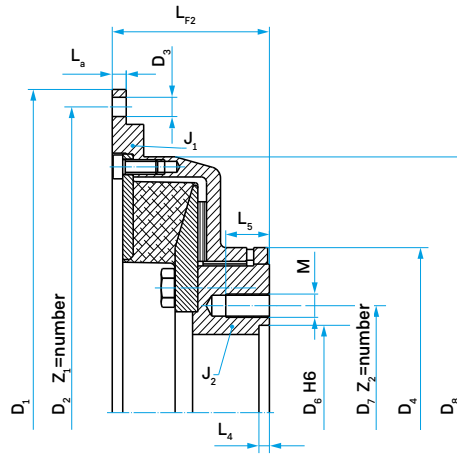

Fig. 1: with fail-safe device

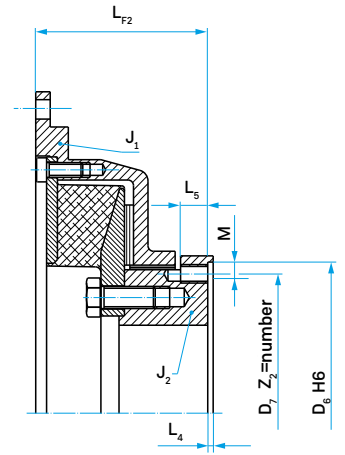

Fig. 2: no fail-safe device

## Coupling details

Engine flywheels with SAE-connecting dimensions according to J 620

Coupling size	Flywheel connection dimensions					SPICER drive shaft connecting dimensions													Total mass <sup>6)</sup> [kg]										
	SAE	D <sub>1</sub>	D <sub>2</sub>	D <sub>3</sub>	Z <sub>1</sub>	D <sub>4</sub>	D <sub>8</sub>	L <sub>3</sub>	L <sub>F1</sub>	L <sub>F2</sub>	Size	Fig.	D <sub>6</sub> H6	D <sub>7</sub>	Z <sub>2</sub> x M <sup>2)</sup>	L <sub>4</sub>	L <sub>5</sub>	J <sub>1</sub>		J <sub>2</sub> <sup>6)</sup>									
	Size	[mm]	[mm]	[mm]		[mm]	[mm]	[mm]	[mm]	[mm]			[mm]	[mm]		[mm]	[mm]	[kgm <sup>2</sup> ]		[kgm <sup>2</sup> ]									
- 15. <sup>1)</sup> F2	8	263.5	244.5	10.5	6						1280/1310	1	60.33	79.38	4 x <sup>3</sup> / <sub>8</sub> "- 24	5	20	0.055	0.010	8.9									
	10	314.3	295.3	10.5	8	140	215	8	57	68	1350/1410		69.85	95.25	4 x <sup>7</sup> / <sub>16</sub> "- 20			0.084		10.3									
- 25. <sup>1)</sup> F2	10	314.3	295.3	10.5	8	144	260	10	75.5	86.5	1280/1310	1	60.33	79.38	4 x <sup>3</sup> / <sub>8</sub> "- 24	5	20	0.148	0.023	15.8									
	11.5	352.4	333.4	10.5							1350/1410		69.85	95.25	4 x <sup>7</sup> / <sub>16</sub> "- 20			0.188		17.2									
- 35. <sup>1)</sup> F2	10	314.3	295.3	10.5	8	180	279	16	79.3	90.3	1480/1550	1	95.25	120.65	4 x <sup>1</sup> / <sub>2</sub> "- 20	6	25	0.144	0.052	17.0									
	11.5	352.4	333.4	10.5							8		96.3	-	1610 <sup>3)</sup>			2		168.28	155.58	8 x <sup>3</sup> / <sub>8</sub> "- 24	1.5	15	0.177	19.2			
	14	466.7	438.2	13.0							8		96.3	-	1610 <sup>3)</sup>			2		168.28	155.58	8 x <sup>3</sup> / <sub>8</sub> "- 24	1.5	15	0.362	23.5			
- 45. <sup>1)</sup> F2	11.5	352.4	333.4	10.5	8	180	314	26	89	100	1480/1550	1	95.25	120.65	4 x <sup>1</sup> / <sub>2</sub> "- 20	6	25	0.281	0.066	23.9									
	14	466.7	438.2	13.0							10		105	-	1610 <sup>3)</sup>			2		168.28	155.58	8 x <sup>3</sup> / <sub>8</sub> "- 24	1.5	15	0.517	0.072	30.5		
- 50. <sup>1)</sup> F2	14	466.7	438.2	13.0	8	210	352	12	100	117	1610	2	168.28	155.58	8 x <sup>3</sup> / <sub>8</sub> "- 24	1.5	30	0.668	0.123	37.2									
											1710 <sup>3)</sup>		196.85	184.15	8 x <sup>3</sup> / <sub>8</sub> "- 24					17	0.138	39.2							
	125	-	1760/1810 <sup>3)</sup>	12 x <sup>7</sup> / <sub>16</sub> "- 20							1.180				46.7														
- 55. <sup>1)</sup> F2	14	466.7	438.2	13.0	8	285	417	28	112	127	1710	2	196.85	184.15	8 x <sup>3</sup> / <sub>8</sub> "- 24	1.5	30	1.087	0.380	55.0									
	18	571.5	542.9	17.0							6				115					130	1760/1810	1	177.80	209.55	12 x <sup>7</sup> / <sub>16</sub> "- 20	7	1.754	0.380	64.4
																					1880/1910				8 x <sup>5</sup> / <sub>8</sub> "- 18				
- 60. <sup>1)</sup> F2	14	466.7	438.2	13.0	8	300	424	25 <sup>4)</sup>	116.5	133.5	1760/1810	2	196.85	184.15	12 x <sup>7</sup> / <sub>16</sub> "- 20	1.5	30	1.100	0.509	64.9									
	18	571.5	542.9	17.0							6				15					131.5	147.5	1880/1910	1	177.80	209.55	8 x <sup>5</sup> / <sub>8</sub> "- 18	7	1.878	76.6
- 70. <sup>1)</sup> F2	18	571.5	542.9	17.0	12	348	510	15	139	160	1880/1910	1	177.80	209.55	8 x <sup>5</sup> / <sub>8</sub> "- 18	7	35	2.681	1.080	106									
	21	673.1	641.4	17.0							12		1880/1910	209.55	249.30			12 x <sup>3</sup> / <sub>4</sub> "- 16		3.747	1.073	117							
- 85. <sup>1)</sup> F2	21	673.1	641.4	17.0	12	440	610	35 <sup>5)</sup>	158.5	179.4	1880/1910	1	177.80	209.55	8 x <sup>5</sup> / <sub>8</sub> "- 18	7	35	6.857	2.229	158									
											1880/1910		209.55	249.30	12 x <sup>3</sup> / <sub>4</sub> "- 16														

- 1) Element version according to "General Technical Data"
- 2) Alternative connection threads on request
- 3) This version not available with fail-safe device
- 4) Centering depth 9 mm
- 5) Centering depth 14 mm
- 6) Values without fail-safe device

### Ordering example

Coupling size      Element version according to "General Technical Data"      Flange version      SAE flywheel connection      SPICER drive shaft      Version with fail-safe device

AC-VSK 50      .WN.      F2.      14.      1610.      DS

Coupling designation: AC-VSK 50 .WN. F2. 14. 1610. DS

# ARCUSAFLEX-VSK

Type AC-VSK...F2 for MECHANICS Cardan Shafts

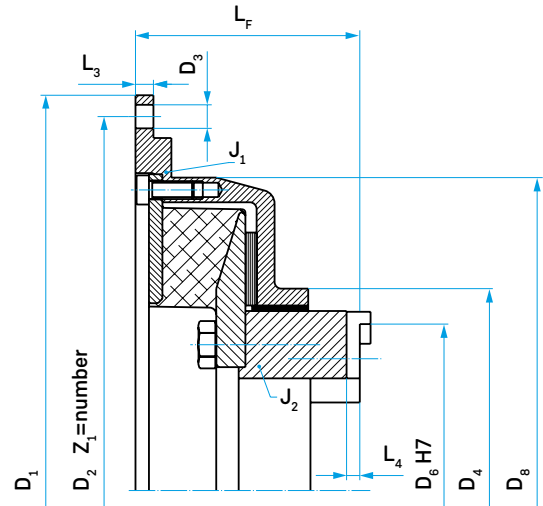
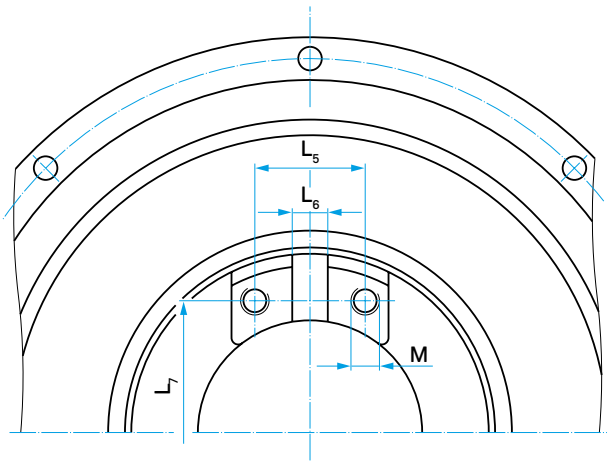



## Coupling details

Engine flywheels with SAE-connecting dimensions according to J 620

Coupling size	Flywheel connection dimensions									MECHANICS drive shaft connecting dimensions									Total mass [kg]
	SAE	D <sub>1</sub>	D <sub>2</sub>	D <sub>3</sub>	Z <sub>1</sub>	D <sub>4</sub>	D <sub>8</sub>	L <sub>3</sub>	L <sub>F</sub>	Size	D <sub>6</sub> H7	L <sub>4</sub>	L <sub>5</sub>	L <sub>6</sub>	L <sub>7</sub>	M	J <sub>1</sub>	J <sub>2</sub>	
	Size	[mm]	[mm]	[mm]		[mm]	[mm]	[mm]	[mm]		[mm]	[mm]	[mm]	[mm]	[mm]	[mm]	[kgm <sup>2</sup> ]	[kgm <sup>2</sup> ]	
- 15. <sup>1)</sup> F2	8	263.5	244.5	10.5	6	140	215	8	83	4C	107.92	3.8	36.5	9.5	87.3	5/16"-24	0.055	0.010	8.8
	10	314.3	295.3	10.5	8					5C	115.06	5.1	42.9	14.26	88.9	3/8"- 24	0.084		10.2
- 25. <sup>1)</sup> F2	10	314.3	295.3	10.5	8	144	260	10	96.5	5C	115.06	5.1	42.9	14.26	88.9	3/8"- 24	0.148	0.022	15.3
	11.5	352.4	333.4	10.5													0.188		16.7
- 35. <sup>1)</sup> F2	10	314.3	295.3	10.5	8	180	279	16	101.3	5C	115.06	5.1	42.9	14.26	88.9	3/8"- 24	0.144	0.048	16.0
	11.5	352.4	333.4	10.5													0.177		17.9
	14	466.7	438.2	13.0						0.362	22.2								
- 45. <sup>1)</sup> F2	11.5	352.4	333.4	10.5	8	180	314	26	111	5C	115.06	5.1	42.9	14.26	88.9	3/8"- 24	0.281	0.063	23.5
	14	466.7	438.2	13.0						6C	140.46	5.1	42.9	14.26	114.3	3/8"- 24	0.517		29.1
- 50. <sup>1)</sup> F2	14	466.7	438.2	13.0	8	210	352	12	130	6C	140.46	5.1	42.9	14.26	114.3	3/8"- 24	0.668	0.115	36.2
										7C	148.39	6	49.2	15.85	117.5	1/2"- 20		0.116	36.3
	18	571.5	542.9	17.0	6	8.5C	165.08	6	71.4	15.85	123.8	1/2"- 20	1.180	0.114	43.1				
- 55. <sup>1)</sup> F2	14	466.7	438.2	13.0	8	285	417	28	155	8C	206.32	6	49.2	15.85	174.6	1/2"- 20	1.087	0.348	52.1
										8.5C	165.08	6	71.4	15.85	123.8	1/2"- 20	1.754		0.353
	18	571.5	542.9	17.0	6	9C	209.52	6	71.4	15.85	168.3	1/2"- 20	0.356	62.2					
- 60. <sup>1)</sup> F2	14	466.7	438.2	13.0	8	300	424	25 <sup>2)</sup>	145.5	8.5C	165.08	6	71.4	15.85	123.8	1/2"- 20	1.100	0.471	62.1
	18	571.5	542.9	17.0	6					15	171.5	9C	209.52	6	71.4	15.85	168.3		1/2"- 20
- 70. <sup>1)</sup> F2	18	571.5	542.9	17.0	12	348	510	15	170	9C	209.52	6	71.4	15.85	168.3	1/2"- 20	2.681	0.964	99.0
	21	673.1	641.4	17.0	12					10C	212.70	9.5	92.1	25.35	165.1	5/8"- 18	3.747		110
- 85. <sup>1)</sup> F2	21	673.1	641.4	17.0	12	440	610	35 <sup>3)</sup>	198.5	12C	289.05	12.5	92.1	25.35	241.3	5/8"- 18	6.857	2.305	157
										15C	260.00	12.5	100	31.78	200.0	3/4"- 16			
										280	280.00	9	92	35.00	227.0	M18			

**i** 1) Element version according to "General Technical Data"  
Version with fail-safe device on request

2) Centering depth 9 mm

3) Centering depth 14 mm

## Ordering example

Coupling size	Element version according to "General Technical Data"	Flange version	SAE flywheel connection	MECHANICS drive shaft connection
AC-VSK 50	.WN.	F2.	14.	7C

Coupling designation: AC-VSK 50 .WN. F2. 14. 7C

# ARCUSAFLEX-VSK

Type AC-VSK...F2.CV for Constant Velocity Shafts

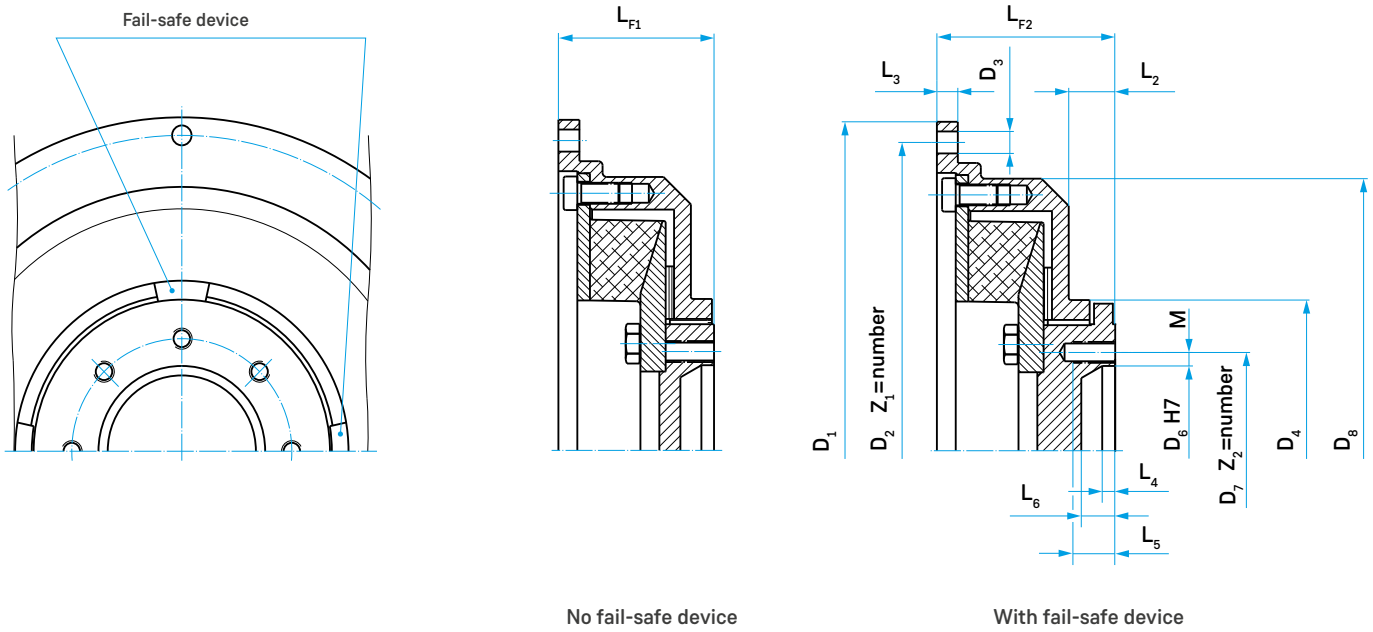

## Coupling details

Engine flywheels with SAE-connecting dimensions according to J 620

Coupling size	Flywheel connection dimensions											Constant velocity shaft connecting dimensions									Total mass <sup>2)</sup> [kg]
	SAE Size	D <sub>1</sub> [mm]	D <sub>2</sub> [mm]	D <sub>3</sub> [mm]	Z <sub>1</sub>	D <sub>4</sub> [mm]	D <sub>8</sub> [mm]	L <sub>2</sub> [mm]	L <sub>3</sub> [mm]	L <sub>F1</sub> [mm]	L <sub>F2</sub> [mm]	Size	D <sub>6</sub> H7 [mm]	D <sub>7</sub> [mm]	Z <sub>2</sub> x M	L <sub>4</sub> [mm]	L <sub>5</sub> [mm]	L <sub>6</sub> [mm]	J <sub>1</sub> [kgm <sup>2</sup> ]	J <sub>2</sub> <sup>2)</sup> [kgm <sup>2</sup> ]	
- 15. <sup>1)</sup> F2	8	263.5	244.5	10.5	6	140	215	18	8	57	68	CV 15	81	94	6 x M10	6	15	16	0.055	0.009	8.1
	10	314.3	295.3	10.5	8														0.084		9.5
- 25. <sup>1)</sup> F2	10	314.3	295.3	10.5	8	144	260	22	10	75.5	86.5	CV 15	81	94	6 x M10	6	20	16	0.148	0.022	15.2
	11.5	352.4	333.4	10.5															0.188		16.6
- 35. <sup>1)</sup> F2	10	314.3	295.3	10.5	8	180	279	28	16	79.3	90.3	CV 21	90	108	6 x M12	8	20	20	0.144	0.049	17.0
	11.5	352.4	333.4	10.5					8			CV 30							112		128
- 45. <sup>1)</sup> F2	11.5	352.4	333.4	10.5	8	180	314	25	26	89	100	CV 30	112	128	6 x M12	12	23	25	0.281	0.055	22.8
	14	466.7	438.2	13.0					10										0.517		28.4
- 50. <sup>1)</sup> F2	14	466.7	438.2	13.0	8	210	352	36	12	103	120	CV 30	112	128	6 x M12	12	25	25	0.668	0.115	36.2
												CV 32		136			155.5	6 x M16			
- 55. <sup>1)</sup> F2	14	466.7	438.2	13.0	8	285	417	35	28	115	130	CV 42	144	165	8 x M16	10	35	26	1.087	0.357	54.7
- 60. <sup>1)</sup> F2	14	466.7	438.2	13.0	8	300	424	48	25 <sup>3)</sup>	119.5	146.5	CV 42	144	165	8 x M16	10	35	26	1.100	0.465	62.0
	18	571.5	542.9	17.0	6				15										1.878		73.7
- 70. <sup>1)</sup> F2	18	571.5	542.9	17.0	12	348	510	46	15	134	155	CV 60	216	245	8 x M20	5	35	25	2.681	0.929	95.7
	21	673.1	641.4	17.0	12														3.747		108

- i 1) Element version according to "General Technical Data"
- 2) Values without fail-safe device
- 3) Centering depth 9 mm

## Ordering example

Coupling size	Element version according to "General Technical Data"	Flange version	SAE flywheel connection	Size of joint Ø	Version with fail-safe device
AC-VSK 50	.WN.	F2.	14.	CV32.	DS

Coupling designation: AC-VSK 50 .WN. F2. 14. CV32. DS

# ARCUSAFLEX-VSK

Type AC-VSK...F1

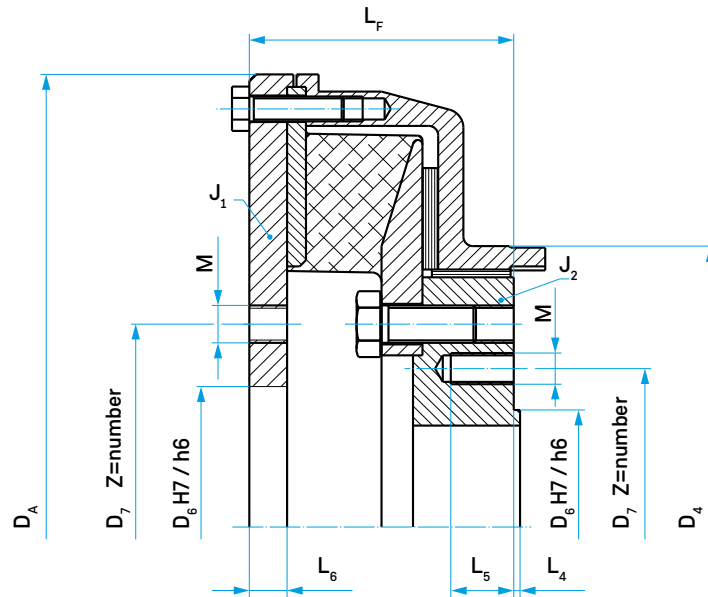

## Coupling details

For mounting between a drive shaft and related adaptor flange. Alternative flange dimensions are available.

Coupling size	D <sub>A</sub> [mm]	D <sub>4</sub> [mm]	L <sub>F</sub> [mm]	Flange and drive shaft connecting dimensions <sup>2)</sup>							J <sub>1</sub> [kgm <sup>2</sup> ]	J <sub>2</sub> [kgm <sup>2</sup> ]	Total mass [kg]
				Flange Ø	D <sub>6</sub> H7/h6 [mm]	D <sub>7</sub> [mm]	Z x M <sup>2)</sup>	L <sub>4</sub> [mm]	L <sub>5</sub> [mm]	L <sub>6</sub> [mm]			
- 15. <sup>1)</sup> .F1	222	140	60	100	57	84.0	6 x M8	2.0	16	10	0.068	0.0086	10.8
				120	75	101.5	8 x M10						
- 25. <sup>1)</sup> .F1	268	144	76.5	120	75	101.5	8 x M10	2.0	20	10	0.164	0.022	17.5
- 35. <sup>1)</sup> .F1	290	180	85.3	120	75	101.5	8 x M10	2.0	20	12	0.222	0.048	23.5
				150	90	130.0	8 x M12						
- 45. <sup>1)</sup> .F1	320	180	92	150	90	130.0	8 x M12	2.5	23	12	0.408	0.063	33.3
- 50. <sup>1)</sup> .F1	360	210	108	150	90	130.0	8 x M12	2.5	25	14	0.659	0.114	42.7
				180	110	155.5	8 x M14						
- 55. <sup>1)</sup> .F1	475	285	130	180	110	155.5	8 x M14	3.0	25	18	1.711	0.350	73.0
				225	140	196.0	8 x M16						
				250	140	218.0	8 x M18	4.0	30				
- 60. <sup>1)</sup> .F1	475	300	134.5	180	110	155.5	8 x M14	3.0	25	20	1.796	0.464	83.4
				225	140	196.0	8 x M16						
				250	140	218.0	8 x M18	4.0	30				
- 70. <sup>1)</sup> .F1	580	348	154	250	140	218.0	8 x M18	4.0	30	20	3.965	0.945	127
				285	175	245.0	8 x M20						
- 85. <sup>1)</sup> .F1	685	440	178.4	285	175	245.0	8 x M20	5.0	35	22	10.23	2.231	212
				315	175	280.0	8 x M22						

**i** 1) Element version according to "General Technical Data"

2) Alternative connecting dimensions and threads on request

## Ordering example

Coupling size	Element version according to "General Technical Data"	Flange version	Drive shaft Ø (part J <sub>2</sub> )	Drive shaft Ø (part J <sub>1</sub> )
---------------	---	----------------	--------------------------------------	--------------------------------------

AC-VSK 50	.WN.	F1.	150.	180
-----------	------	-----	------	-----

Coupling designation: AC-VSK 50 .WN. F1. 150. 180

# ARCUSAFLEX-VSK

Type AC-VSK F1W

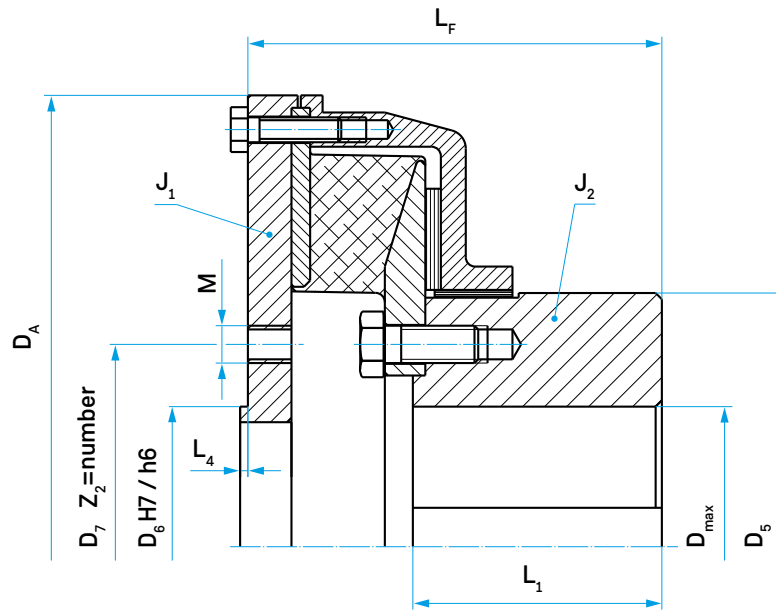

## Coupling details

To connect a shaft to a drive shaft

Coupling size	D <sub>A</sub> [mm]	D <sub>5</sub> [mm]	D <sub>max</sub> [mm]	L <sub>1</sub> [mm]	L <sub>F</sub> [mm]	Drive shaft connecting dimensions <sup>2)</sup>					J <sub>1</sub> [kgm <sup>2</sup> ]	J <sub>2</sub> [kgm <sup>2</sup> ]	Total mass [kg]
						Flange ∅	D <sub>6</sub> H7/h6 [mm]	D <sub>7</sub> [mm]	Z x M <sup>2)</sup>	L <sub>4</sub> [mm]			
- 15. <sup>1)</sup> .F1	222	123	60	65	104	100	57	84.0	6 x M8	2.0	0.080	0.015	15.3
						120	75	101.5	8 x M10				
- 25. <sup>1)</sup> .F1	268	123	60	65	115.5	120	75	101.5	8 x M10	2.0	0.164	0.028	19.9
- 35. <sup>1)</sup> .F1	290	163	90	80	134.3	120	75	101.5	8 x M10	2.0	0.187	0.067	26.5
						150	90	130.0	8 x M12	2.5			
- 45. <sup>1)</sup> .F1	320	163	90	80	139	150	90	130.0	8 x M12	2.5	0.320	0.077	32.7
- 50. <sup>1)</sup> .F1	360	183	100	100	171	150	90	130.0	8 x M12	2.5	0.539	0.158	47.2
						180	110	155.5	8 x M14	3.0			
- 55. <sup>1)</sup> .F1	475	255	120	140	230	180	110	155.5	8 x M14	3.0	1.653	0.638	104
						225	140	196.0	8 x M16	4.0			
						250	140	218.0	8 x M18				
- 60. <sup>1)</sup> .F1	475	260	120	140	222.5	180	110	155.5	8 x M14	3.0	1.730	0.729	109
						225	140	196.0	8 x M16	4.0			
						250	140	218.0	8 x M18				
- 70. <sup>1)</sup> .F1	580	305	150	170	275	250	140	218.0	8 x M18	4.0	4.171	1.663	184
						285	175	245.0	8 x M20	5.0			

**i** 1) Element version according to "General Technical Data"

2) Other connection dimensions and thread on request

## Ordering example

Coupling size	Element version according to "General Technical Data"	Flange version	Drive shaft flange ∅
AC-VSK 50	.WN.	F1W.	150

Coupling designation: AC-VSK 50 .WN. F1W. 150